



Dishwashing

EVO Generation - Concept

GLASSWASHER CO-350 DD

DIMENSIONS

		<u>Article</u>	<u>Packed</u>
Length	mm	430,00	510,00
Depth	mm	475,00	635,00
Height	mm	650,00	820,00
Weigth	Kg	34,00	37,00
Volumen	m3		0,27

ELECTRICITY

<u>Electric power</u>	KW	
230V -1+N		2x2,5+T - 25 A
230V - III		3x1,5+T - 16 A
400V - III+N		4x1,5+T - 10 A

WATER

Water consumption (lit/h)	60,00
Pressure (Kg/cm2)	2 ÷ 4

GAS

Not used

STEAM

Not used

AIR

Not used

LEVEL SOUND

(dB) **65,00**

GLASSWASHER CO-350 DD

Front loading glasswasher - EVO Generation - Concept range.
Basket size: 350 x 350 mm.
Hourly production: 30 baskets/hour.
Clearance (max ware height): 220 mm.
Valid for dishes Ø 190 mm.
Wash cycle: 120".

Made of stainless steel.
The door has double skin.

Double rotating wash and rinse systems, above and below, made of stainless steel.

Wash pump: 260 W.
Tank with 2.0 kW heating element.
Tank capacity: 11 litres.
Boiler with 2.4 kW heating element.
Boiler capacity: 4 litres.
Water consumption: 2 litres/rinse.
Thermostatic temperature control: washing at 60 °C and rinsing at 90 °C.
Security thermostats.
Built-in automatic rinse dispenser and detergent doser.
Built-in non-return valve.
Safety magnetic switch for door opening.
Adjustable legs.

Total power: 2.66 kW.
Dimensions: 430 x 475 x 650 mm.

Equipment: one basket 350x350, one supplement for saucers and one cutlery container.

Connections points	X	Y	Z	Diameter	Information
ELECTRICITY	210	50	65		
SOFT COLD WATER	305	50	65	3/4"	
DRAIN	370	50	65	30 x 25	

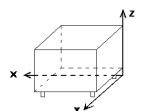

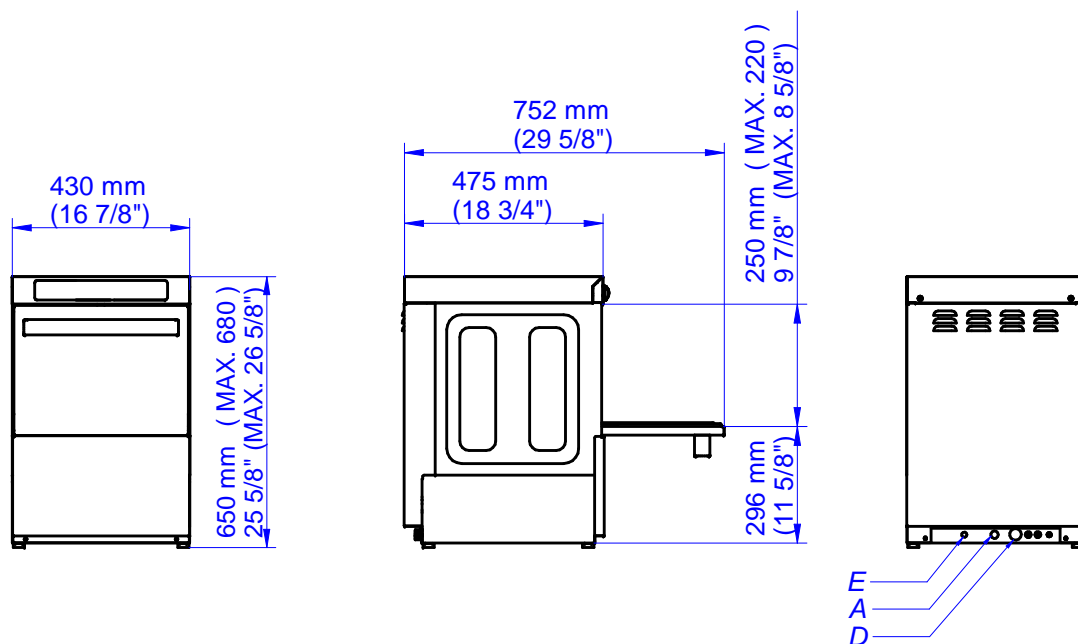

SOLO MODELOS "B"
ONLY "B" MODELS
SEULEMENT MODÈLES "B"

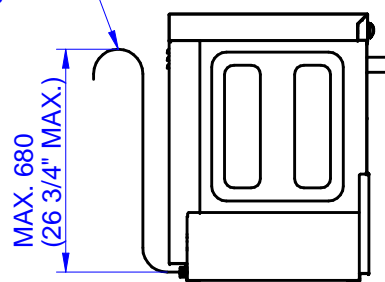

A: ENTRADA DE AGUA
E: ALIMENTACIÓN ELÉCTRICA
D: DESAGÜE

A: WATER INLET
E: ELECTRICAL CONNECTION
D: DRAIN

A: ARRIVÉE D'EAU
E: CONNEXION ÉLECTRIQUE
D: VIDANGE