



Dishwashing

EVO Generation - Concept

GLASSWASHER CO-402 COLD B

DIMENSIONS

		Article	Packed
Length	mm	470,00	530,00
Depth	mm	520,00	680,00
Height	mm	720,00	890,00
Weigth	Kg	36,00	40,00
Volumen	m3		0,32

ELECTRICITY

Electric power	KW	
230V -1+N		2x2,5+T - 25 A
230V - III		3x1,5+T - 16 A
400V - III+N		4x1,5+T - 10 A

WATER

Water consumption (lit/h)	80,00
Pressure (Kg/cm2)	2 ÷ 4

GAS

Not used

STEAM

Not used

AIR

Not used

LEVEL SOUND

(dB) 65,00

GLASSWASHER CO-402 COLD B

Front loading glasswasher - EVO Generation - Advance range.
Basket size: 400 x 400 mm.
Hourly production: 40 baskets/hour .
Clearance (max ware height): 275 mm.
Valid for dishes Ø 270 mm.
Wash cycles: 90" - 120" - 180".
Electronic control. Digital displays.
Selector for an optional cold rinse at the end of the cycle.

Made of stainless steel.
The door has double skin.
Double rotating wash and rinse systems, above and below, made of stainless steel.
Wash pump: 260 W.
Drain pump: 30 W. Drainage cycle.
Tank with 2.0 kW heating element.
Tank capacity: 13 litres.
Boiler with 2.8 kW heating element.
Boiler capacity: 4 litres.
Water consumption: 2.4 litres/rinse.
Thermostatic temperature control: washing at 60 °C and rinsing at 90 °C.
Security thermostats.
Built-in automatic rinse.
Built-in non-return valve.
Safety magnetic switch for door opening.
Adjustable legs.

Total power: 3.06 kW.
Dimensions: 470 x 520 x 720 mm.

Equipment: one basket 400x400, one supplement for dishes and one cutlery container.

Connections points	X	Y	Z	Diameter	Information
ELECTRICITY	210	50	65		
SOFT COLD WATER	305	50	65	3/4"	
DRAIN	370	50	65	30 x 25	

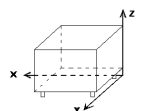

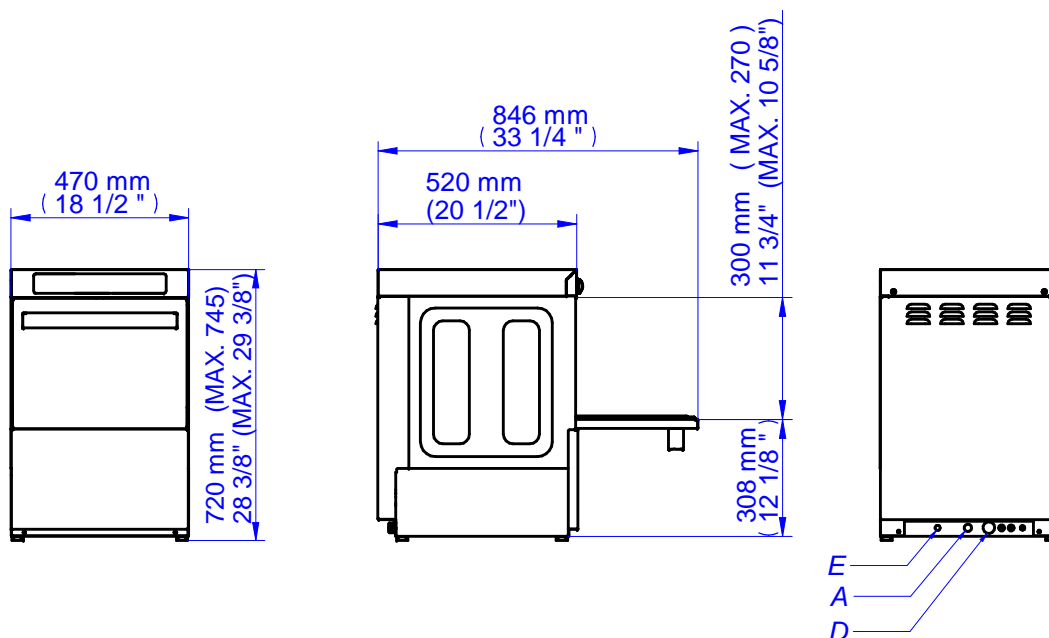

SOLO MODELOS "B"
ONLY "B" MODELS
SEULEMENT MODÈLES "B"

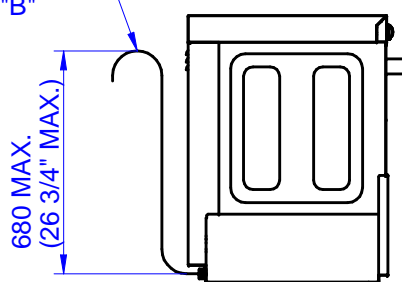

A: ENTRADA DE AGUA
E: ALIMENTACIÓN ELÉCTRICA
D: DESAGÜE

A: WATER INLET
E: ELECTRICAL CONNECTION
D: DRAIN

A: ARRIVÉE D'EAU
E: CONNEXION ÉLECTRIQUE
D: VIDANGE